

Piping All-position Automatic Welding Machine(GTAW)



Piping All-position Automatic Welding Machine(GTAW)



带弧长横摆功能的标准机头

Piping All-position Automatic Welding Machine(GTAW)

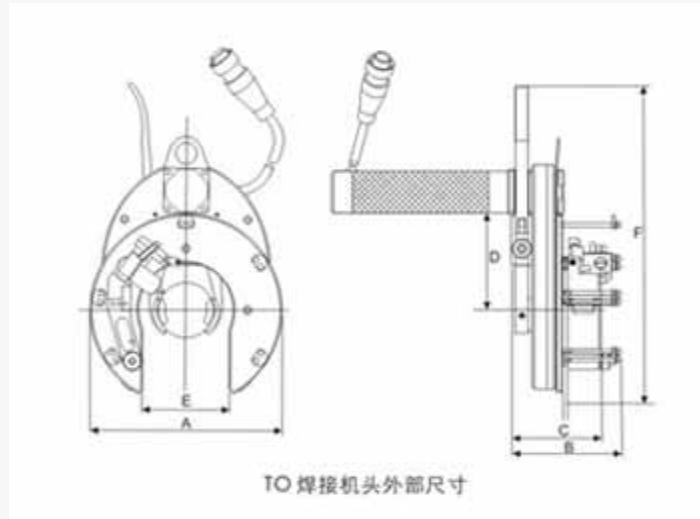

TO 焊接机头外部尺寸

Piping All-position Automatic Welding Machine(GTAW)

Model: PFAWM-1HC/02C/2HC/04C/06C/08C

Performance Characteristics:

1. Without Wire Feeder/ All-position auto-tig Wire Feeder/Pulse Jointing Machine

2. Be suitable to spot operation due to the structure, rotation and rotational inertia
3. Arc length adjustment and Yaw can be used in head above TO77
4. Used in the welding of thick pipelines
5. Long working time
6. Circulating Water Cooling outside
7. Die without punch
8. Surface and tungsten electrode keep constant
9. Impulse-counting connect with control system
10. Pipe materials: carbon steel, alloy steel, stainless steel and cryogenic steel.
11. Welding: tube-tube, pipe-pipe, tube-elbow, tube-flange, flange-flange, flange- elbow (dummy tubes for connection when necessary).
12. Connected with EWA306/ EWA160 program, auto-digital Inverter Power for TIG Welding

Technical parameter:

1. Pipe diameter: $\Phi 15-43$ 、 $\Phi 19-60$ 、 $\Phi 20-77$ 、 $\Phi 42-130$ 、 $\Phi 64-180$ 、 $\Phi 120-230$
2. Pipe materials: carbon steel, alloy steel, stainless steel and cryogenic steel.
3. Welding Speed: 0.37-7.4、0.25-5.02 、0.19-3.82、0.115-2.29、0.089-1.78、0.052-1.04
4. Cooling Mode : water cooling
5. Angle of Welding Gun : 0-45